

Schilling Robotics RigMaster Manipulator

For nearly every TITAN™ 4 manipulator in the market, there is a RigMaster supporting its mission. Its titanium construction makes it durable and reliable in heavy work-class missions.

- ▶ Structural strength and long service life
- ▶ Large operating envelope
- ▶ Highest lift-to-weight ratio in its class
- ▶ Interchangeable jaw configurations
- ▶ Boom function extends arm length by 305mm
- ▶ Standard depth rating of 6,500msw

The RigMaster is a five-function, rate-controlled, heavy-lift grabber arm that can be mounted on a wide range of subsea ROVs. It is engineered for the strength needed to withstand the industry's harsh and repetitive needs day after day. The grabber arm can be used to grasp and lift heavy objects or to anchor the ROV by clamping the gripper around a structural member at the work site.

It is constructed to be reliable in situations that require rugged operation. The arm's linear actuators have been life-tested under full load for 250,000 cycles

with minimal wear. The actuators use the latest cap seal technology to minimize leakage, ensuring long life and minimal maintenance. Its construction is of primarily titanium for structural strength, light weight, corrosion resistance, and extraordinary resistance to damage from collisions. RigMaster manipulators have a proven track record of reliability in the world's most demanding subsea environments.

System configurations

On an ROV, this arm is typically paired with a dexterous manipulator arm such as a TITAN™, Atlas™ P, or ORION™ model. The standard arm is configured for left-hand installation, so that a dexterous arm can be mounted on the right. The RigMaster arm can be stowed vertically or horizontally to accommodate a range of ROV configurations. No electrical connections are required for the arm. Each joint or function is supplied by two hydraulic hoses that can be controlled with simple, customer-supplied valves and a switch box. An optional ergonomic rate hand controller is available for manipulator operation.



Lift to Weight Ratio

The RigMaster has the highest lift-to-weight ratio of any manipulator in its class. Weighing only 48kg in seawater, its titanium linear actuators allow the manipulator to lift 270kg when the boom is retracted and 181kg at full arm extension. The wrist, which provides continuous 360-degree rotation, is driven by a high-torque, low-speed gerotor hydraulic motor that produces 205Nm of torque.

Range
of Motion,
Top View

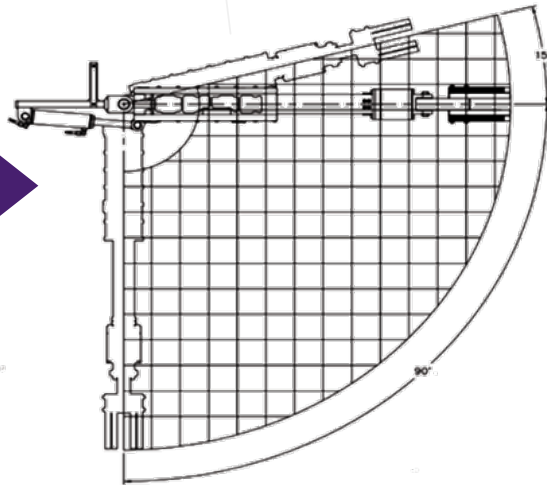

Range
of Motion,
Side View

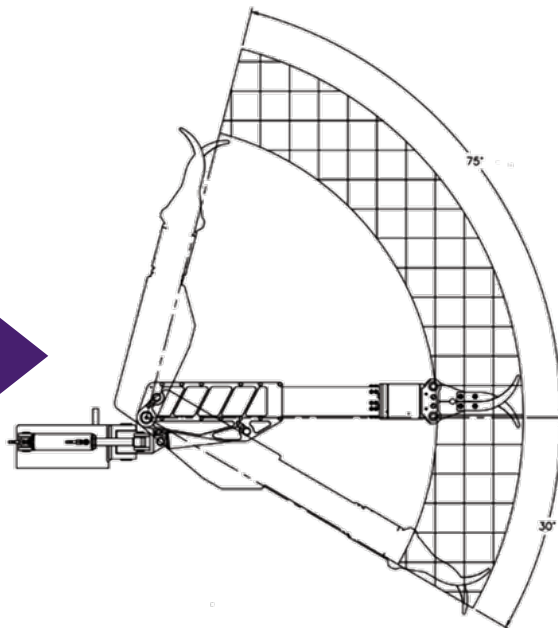

7 P/R Specifications

Reach:	1,372mm
Type:	Rate controlled
Functions:	5
Materials:	Anodized aluminum, stainless steel, titanium

Arm Specifications

Standard Depth:	6,500 msw
Weight in Air:	64kg
Weight in Water:	48kg
Lift at Full Extension:	181kg
Maximum Lift, Nominal:	270kg
Standard Gripper Opening:	289mm
Grip Force, Nominal:	4,448N
Wrist Torque, Nominal:	205Nm
Wrist Rotate, Continuous:	6-35rpm

Actuator Function

Base Yaw:	Linear, 105°
Shoulder Pitch:	Linear, 105°
Boom, Extend/ Retract:	Linear, 305mm
Wrist Pitch:	Linear, 120°
Wrist Rotate:	Gerotor, 360°
Gripper, Standard:	Linear, 284mm

Hydraulic Requirements

Fluid:	Mineral, Glycol, or Synthetic
Viscosity:	10-200 cSt
Available Flow:	5.7 - 19 lpm
Max. Pressure:	3,000 psi
Max Fluid Temperature:	54°
Fluid Cleanliness:	ISO 4406 14/11
Filtration:	10 microns

Corporate
TechnipFMC PLC
11740 Katy Freeway
Houston, Texas 77079 (USA)
P: +1 281 591 4000

Schilling Robotics LLC
201 Cousteau Place
Davis, California 95618 (USA)
P: +1 530 753 6718